

movexii.com

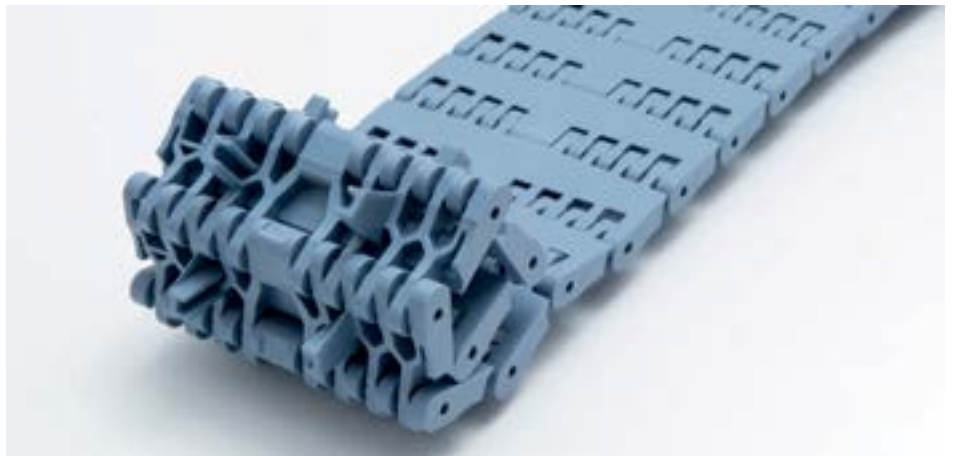

Metric Version
2019



Movex[®]
PRODUCT CATALOG

Movex[®]

Facts

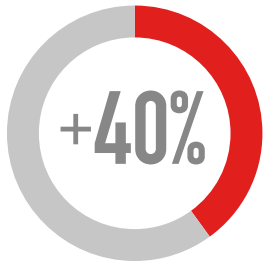

PRODUCTION
CAPACITY

16.500 Mq²
OF PRODUCTION SPACE

REFERENCE YEAR 2018

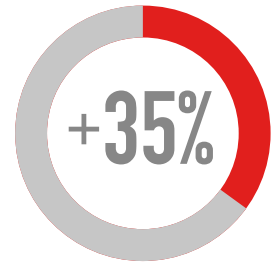

WAREHOUSE
CAPACITY

>23.000 DIFFERENT
PRODUCTS AVAILABLE

>200 EMPLOYEES
AROUND THE WORLD



MISSION

Creating value through innovative development of ideas, supporting our partners with professionalism, flexibility and effectiveness.

VISION

Reaching market leadership as a reliable and precise supplier. Planning the future without losing sight of our history and the values that allow our growth.

WE CREATE SOLUTIONS



In the new headquarters **Movex** designs and manufactures high quality components for the food, beverage, packaging, automotive and automation industries.

Movex meets your needs for standard and custom products in a dynamic and responsive way ensuring the best performance product with an attractive market price.

RESEARCH & DEVELOPMENT



The rich experience that **Movex** has acquired over the years shows that care and innovation of products are essential to guarantee constant quality.

Thanks to the investments as well as developing strategic departments **Movex** has created new space where research and innovation become concrete tools to satisfy customers' requirements.

WE SUPPORT YOU



A top service level is the goal of a qualified Engineering and Sales team with the objective of presenting **Movex** as a supplier of excellence to all clients.

Through a distribution/network which spans the globe, **Movex** offers technical support and a careful after-sales service, always at your disposal.

CONTACT US

Movex S.p.A.

Via Industria, 22 - 24060 Castelli Calepio (BG)

P +39 035 8359711 | F +39 035 4420873 | info@movexii.com

Movex around the world

 **Movex GmbH**
P +49-6204-9375-0

 **Movex AG India**
P +91-120-4159660-62

 **Movex USA Inc.**
P +1-919-274-5477

 **Movex Brasil Ltda**
P +55-15-3141-2550

 **Movex UK Ltd.**
P +44-77-20678442

 **Movex SA de CV**
P +52-1-3318458187

 **Movex France**
P +33-0640592049

 **Movex Nederland**
P +31-630-994850

 **Movex Russia**
P +7 (495) 925-88-56

 **Movex Ukraine**
P +380-667507756

Movex[®] ***is online!***

Always connected.

*Consult our catalog
from your favorite
device and request
a free quotation.*

www.movexii.com

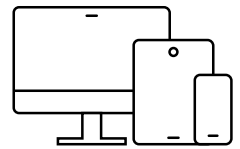

RESPONSIVE



Movex[®] ***is App!***



*Stay updated
on our latest news.*

*Discover more about us
and our products.*

***Download it free today
from the App store!***



Movex

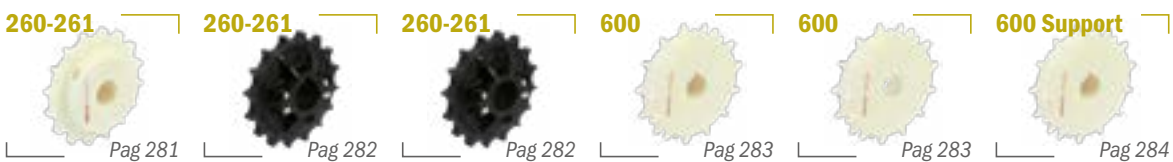
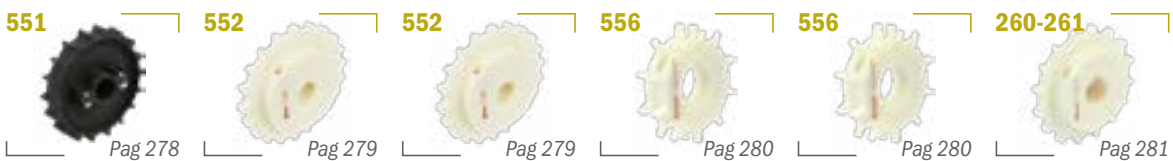
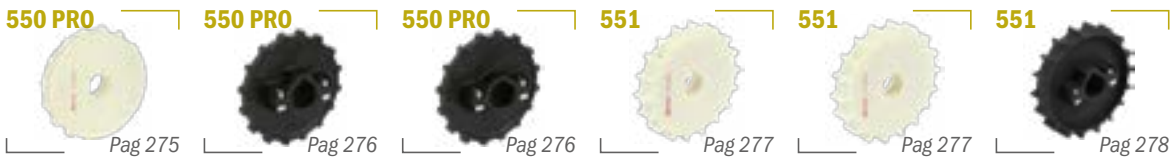
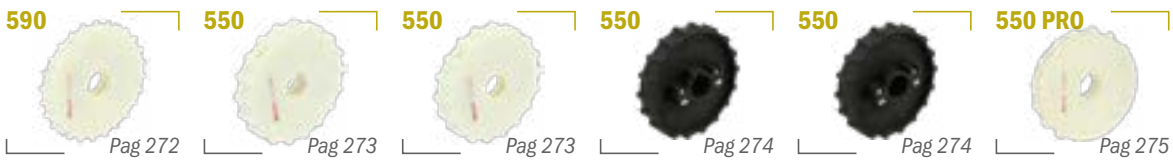
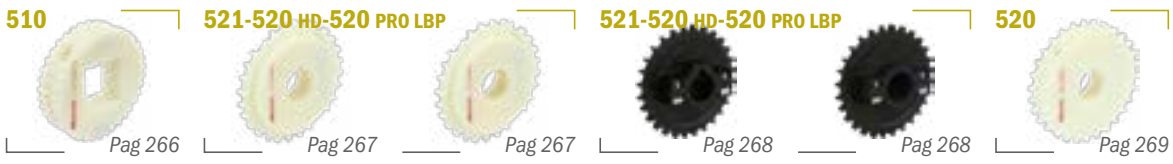

Info
Material:

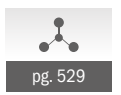

510

Ruota traino divisa, fresata

Split drive sprocket, machined / geteiltes Antriebskettenrad, gefräst

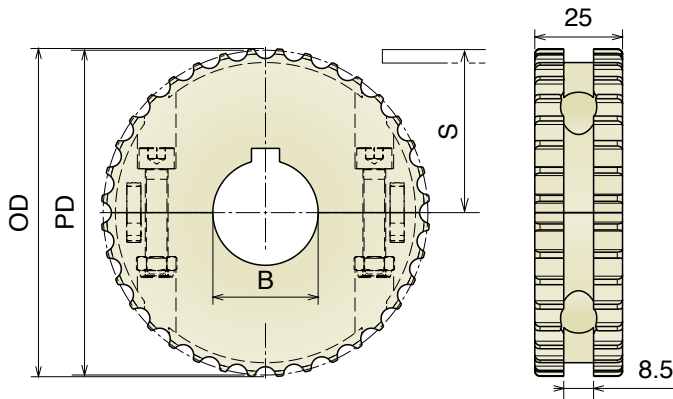

Part	Article-Nr.	Z-	Bore	PD	OD	S
1599	159936E	16*	20	41	40,2	16,65
1599	159896E	20	25	51,5	51,5	22,3
1601	160101E	18*	25	46,5	47,3	20,2
1602	160111E		20*20	□		
1602	160201E	24*	25	61,8	62,6	27,9
1603	160206E		25*25	□		
1603	160301	36	25	92,6	93,5	43,3
1603	160302		30			
1603	160303		35			
1603	160304		40			
1603	160306		25*25	□		
1603	160307		30*30	□		
1603	160308		40*40	□		

*Sprocket z-16, z-18, z-20 and z-24 are supplied non-split

Materiale / Material / Materialien:

Poliamide/Polyamide/Polyamid

Viti: Acciaio inox/Screws: Stainless steel/Schrauben: Edelstahl

Dadi: ferro zincato/Nuts: zinc plated steel/Mutter: verzinkter Stahl

521-520 HD-520 PRO LBP

Ruote per tappeti / Belt sprockets / Kettenräder für Mattenketten

521-520 HD-520 PRO LBP

Ruota traino divisa, fresata
Split drive sprocket, machined
geteiltes Antriebskettenrad, gefräst

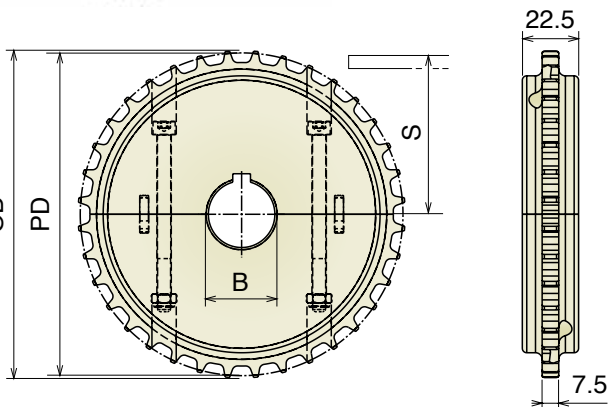

Part	Article-Nr.	Z-	Bore	PD	OD	S
1561	156101	28	25	113,4	115,4	52,4
1561	156102		30			
1561	156103		35			
1561	156104		40			
1561	156106		25* 25	□		
1561	156107		30* 30	□		
1561	156108		40* 40	□		
1562	156201	36	25	145,7	147,7	68,5
1562	156202		30			
1562	156203		35			
1562	156204		40			
1562	156206		25* 25	□		
1562	156207		30* 30	□		
1562	156208		40* 40	□		
1563	156301	38	25	153,8	155,8	72,6
1563	156302		30			
1563	156303		35			
1563	156304		40			
1563	156306		25* 25	□		
1563	156307		30* 30	□		
1563	156308		40* 40	□		
1564	156401	40	25	161,9	163,8	76,6
1564	156402		30			
1564	156403		35			
1564	156404		40			
1564	156406		25* 25	□		
1564	156407		30* 30	□		
1564	156408		40* 40	□		

Ruota rinvio divisa, fresata

Split idler sprocket, machined / geteiltes Umlenrad, gefräst

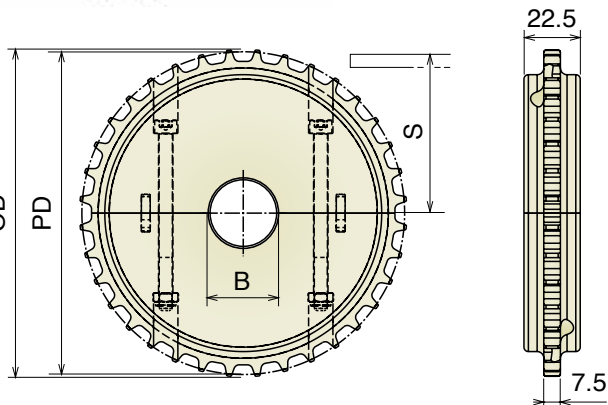

Part	Article-Nr.	Z-	Bore	PD	OD	S
1561	156150	28	18*	113,4	115,4	52,4
1561	156151		25			
1561	156152		30			
1561	156153		35			
1561	156154		40			
1562	156250	36	18*	145,7	147,7	68,5
1562	156251		25			
1562	156252		30			
1562	156253		35			
1562	156254		40			
1563	156350	38	18*	153,8	155,8	72,6
1563	156351		25			
1563	156352		30			
1563	156353		35			
1563	156354		40			
1564	156450	40	18*	161,9	163,8	76,6
1564	156451		25			
1564	156452		30			
1564	156453		35			
1564	156454		40			

*Plain Bore

521-520 HD-520 PRO LBP

Ruote per tappeti / Belt sprockets / Kettenräder für Mattenketten

Materiali / Material / Materialien:

Poliammide/Polyamide/Polyamid

Viti: Acciaio inox/Screws: Stainless steel/Schrauben: Edelstahl

Dadi: ferro zincato/Nuts: zinc plated steel/Mutter: verzinkter Stahl

521-520 HD-520 PRO LBP

Ruota traino divisa, stampata
Split drive sprocket, molded
geteiltes Antriebskettenrad, gespritzt

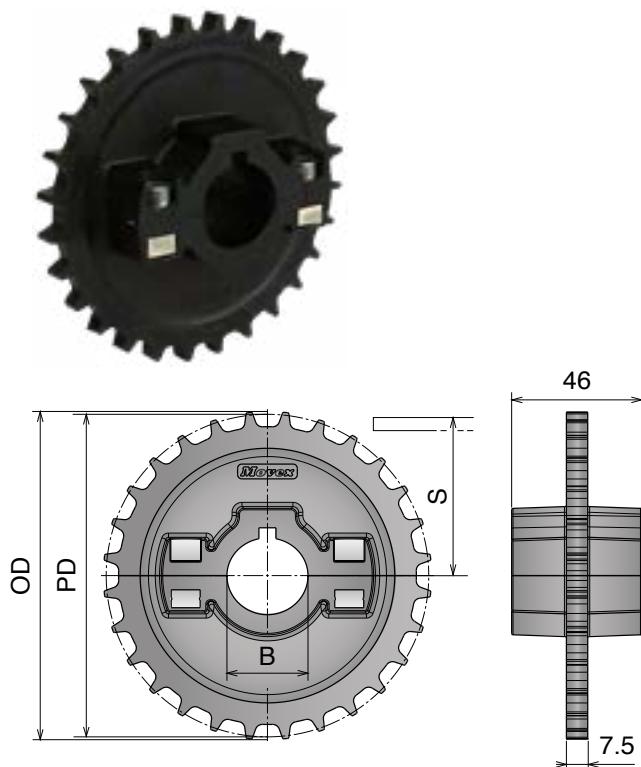

Part	Article-Nr.	Z-	Bore	PD	OD	S
1630	163001	24	25	97,3	99,3	44,3
1630	163002		30			
1630	163003		35			
1630	163004		40			
1630	163006		25*25	□		
1630	163007		30*30	□		
1630	163008		40*40	□		
1631	163101	28	25	113,4	115,4	52,4
1631	163102		30			
1631	163103		35			
1631	163104		40			
1631	163106		25*25	□		
1631	163107		30*30	□		
1631	163108		40*40	□		
1632	163201	36	25	145,7	147,7	68,5
1632	163202		30			
1632	163203		35			
1632	163204		40			
1632	163206		25*25	□		
1632	163207		30*30	□		
1632	163208		40*40	□		

Ruota rinvio divisa, stampata
Split idler sprocket, molded / geteiltes Umlenkrad, gespritzt

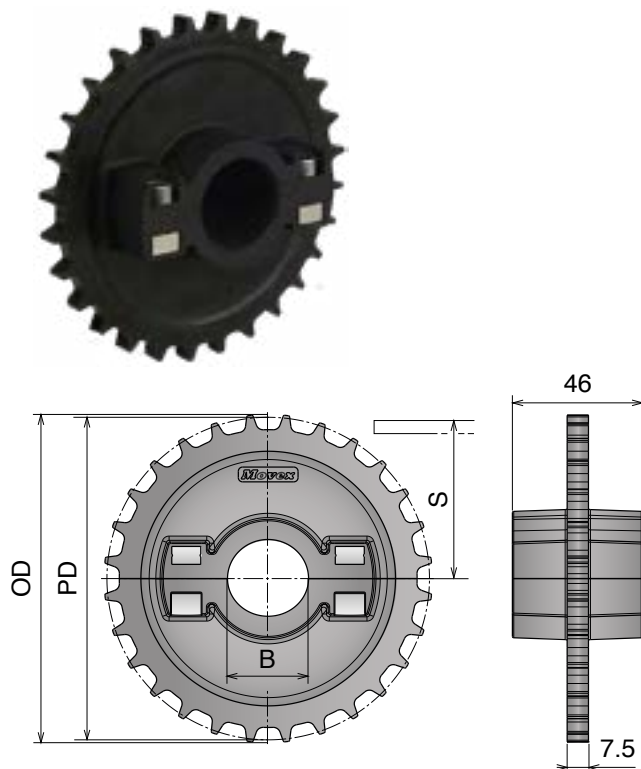

Part	Article-Nr.	Z-	Bore	PD	OD	S
1630	163051	24	25	97,3	99,3	44,3
1630	163052		30			
1630	163053		35			
1630	163054		40			
1631	163151	28	25	113,4	115,4	52,4
1631	163152		30			
1631	163153		35			
1631	163154		40			
1632	163251	36	25	145,7	147,7	68,5
1632	163252		30			
1632	163253		35			
1632	163254		40			

Materiale / Material / Materialien:

Poliamide/Polyamide/Polyamid

Viti: Acciaio inox/Screws: Stainless steel/Schrauben: Edelstahl

Dadi: ferro zincato/Nuts: zinc plated steel/Mutter: verzinkter Stahl

520 Ruota traino divisa, fresata

Split drive sprocket, machined / geteiltes Antriebskettenrad, gefräst

Delivery: **Easy** Standard

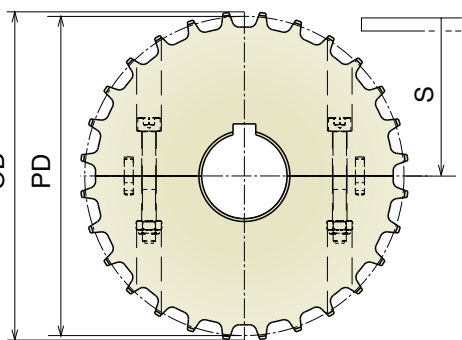

Part	Article-Nr.	Z-	Bore	PD	OD	S
1501	150101	28	25	113,4	115,4	52,4
1501	150102		30			
1501	150103		35			
1501	150104		40			
1501	150106		25* 25	□		
1501	150107		30* 30	□		
1501	150108		40* 40	□		
1502	150201	36	25	145,7	147,7	68,5
1502	150202		30			
1502	150203		35			
1502	150204		40			
1502	150206		25* 25	□		
1502	150207		30* 30	□		
1502	150208		40* 40	□		
1503	150301	38	25	153,8	155,8	72,6
1503	150302		30			
1503	150303		35			
1503	150304		40			
1503	150306		25* 25	□		
1503	150307		30* 30	□		
1503	150308		40* 40	□		
1504	150401	40	25	161,9	163,8	76,6
1504	150402		30			
1504	150403		35			
1503	150404		40			
1504	150406		25* 25	□		
1504	150407		30* 30	□		
1504	150408		40* 40	□		

Ruota rinvio divisa, fresata

Split idler sprocket, machined / geteiltes Umlenrad, gefräst

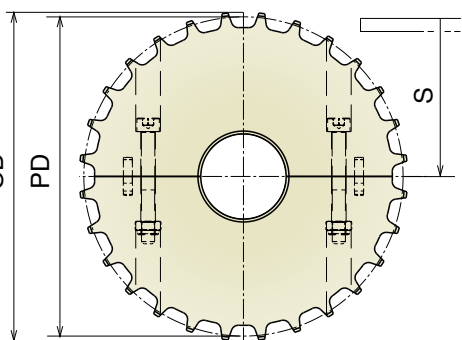

Part	Article-Nr.	Z-	Bore	PD	OD	S
1501	150150	28	18*	113,4	115,4	52,4
1501	150151		25			
1501	150152		30			
1501	150153		35			
1501	150154		40			
1502	150250	36	18*	145,7	147,7	68,5
1502	150251		25			
1502	150252		30			
1502	150253		35			
1502	150254		40			
1503	150350	38	18*	153,8	155,8	72,6
1503	150351		25			
1503	150352		30			
1503	150353		35			
1503	150354		40			
1504	150450	40	18*	161,9	163,8	76,6
1504	150451		25			
1504	150452		30			
1504	150453		35			
1504	150454		40			

*Plain Bore

Materiale / Material / Materialien:

Poliammide rinforzato / Polyamide reinforced / Verstärktes Polyamid
 Viti: Acciaio inox / Screws: Stainless steel / Schrauben: Edelstahl
 Dadi: Ottone nichelato / Nuts: Nickel plated brass / Mutter: Messing

520

Ruota traino divisa, stampata

Split drive sprocket, molded / geteiltes Antriebskettenrad, gespritzt

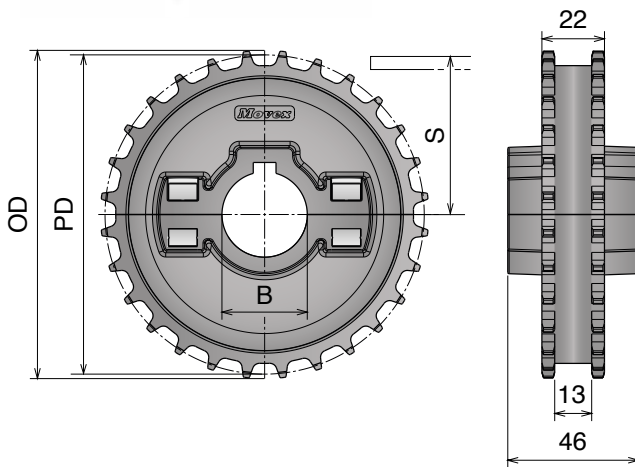
Delivery: **Easy** Standard

Ruota rinvio divisa, stampata

Split idler sprocket, molded / geteiltes Umlenrad, gespritzt

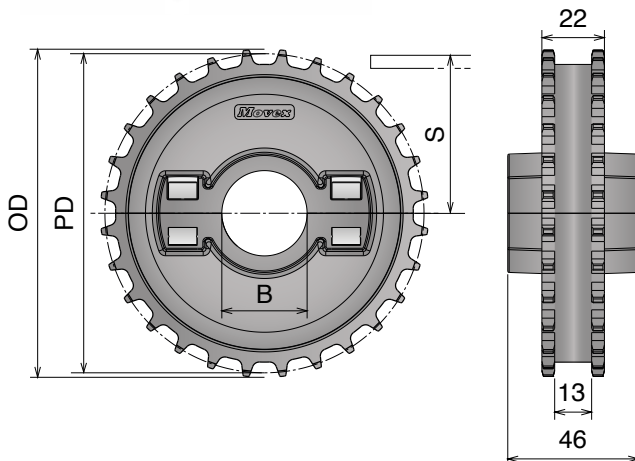

Part	Article-Nr.	Z-	Bore	PD	OD	S
1505	150501	24	25	97,3	99,3	44,3
1505	150502		30			
1505	150503		35			
1505	150504		40			
1505	150506		25*25	□		
1505	150507		30*30	□		
1505	150508		40*40	□		
1506	150601	28	25	113,4	115,4	52,4
1506	150602		30			
1506	150603		35			
1506	150604		40			
1506	150606		25*25	□		
1506	150607		30*30	□		
1506	150608		40*40	□		
1507	150701	36	25	145,7	147,7	68,5
1507	150702		30			
1507	150703		35			
1507	150704		40			
1507	150706		25*25	□		
1507	150707		30*30	□		
1507	150708		40*40	□		

Part	Article-Nr.	Z-	Bore	PD	OD	S
1505	150551	24	25	97,3	99,3	44,3
1505	150552		30			
1505	150553		35			
1505	150554		40			
1506	150651	28	25	113,4	115,4	52,4
1506	150652		30			
1506	150653		35			
1506	150654		40			
1507	150751	36	25	145,7	147,7	68,5
1507	150752		30			
1507	150753		35			
1507	150754		40			

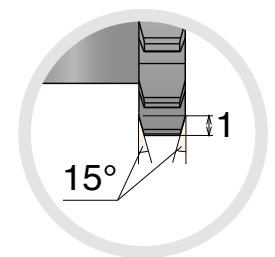

Materiale / Material / Materialien:

Poliammide/Polyamide/Polyamid

Viti: Acciaio inox/Screws: Stainless steel/Schrauben: Edelstahl

Dadi: ferro zincato/Nuts: zinc plated steel/Mutter: verzinkter Stahl

525-530

Ruote per tappeti / Belt sprockets / Kettenräder für Mattenketten

525-530

Ruota traino divisa, fresata

Split drive sprocket, machined / geteiltes Antriebskettenrad, gefräst

Delivery: **Easy** **Standard**

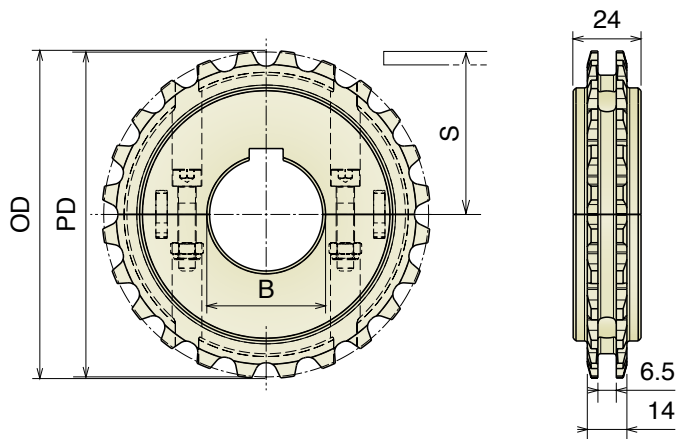

Part	Article-Nr.	Z-	Bore	PD	OD	S
1581	158101E	12**	25	58,1	58,2	24,1
1581	158106E		25x25 □			
1582	158201E	16**	25	77,1	77,7	33,6
1582	158202E		30			
1582	158206E		25x25 □			
1582	158207E		30x30 □			
1583	158301	24	25	114,9	115,5	52,5
1583	158302		30			
1583	158303		35			
1583	158304		40			
1583	158306		25x25 □			
1583	158307		30x30 □			
1583	158308		40x40 □			
1584	158401	32	25	153,4	154,8	71,75
1584	158402		30			
1584	158403		35			
1584	158404		40			
1584	158406		25x25 □			
1584	158407		30x30 □			
1584	158408		40x40 □			

**Idler sprocket Z-12 and Z-16 are supplied non-split.

Ruota rinvio divisa, fresata

Split idler sprocket, machined / geteiltes Umlenrad, gefräst

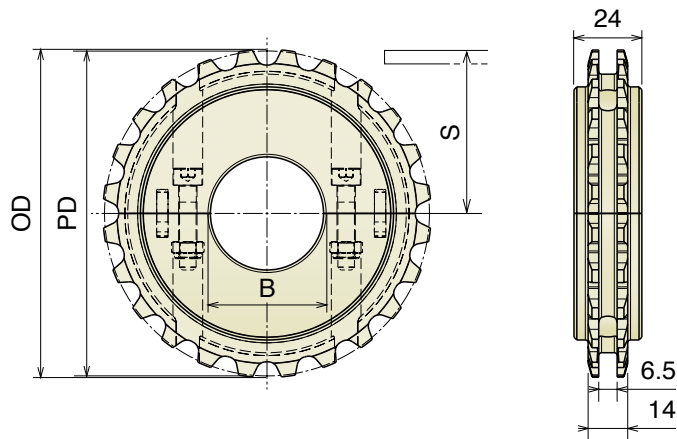

Part	Article-Nr.	Z-	Bore	PD	OD	S
1581	158150E	12**	18*	58,1	58,2	24,1
1581	158151E		25			
1582	158250E	16**	18*	77,1	77,7	33,6
1582	158251E		25			
1582	158252E		30			
1583	158350	24	18*	114,9	115,5	52,5
1583	158351		25			
1583	158352		30			
1583	158353		35			
1583	158354		40			
1584	158450	32	18*	153,4	154,8	71,75
1584	158451		25			
1584	158452		30			
1584	158453		35			
1584	158454		40			

**Idler sprocket Z-12 and Z-16 are supplied non-split.

*Plain Bore

590

Ruota traino divisa, fresata

Split drive sprocket, machined / geteiltes Antriebskettenrad, gefräst

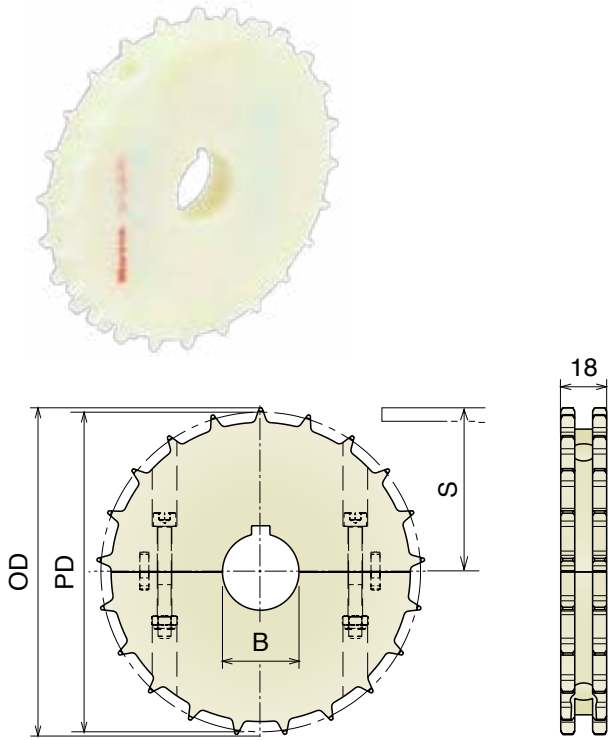

Part	Article-Nr.	Z-	Bore	PD	OD	S
1511	151101	17	25	100,7	103,4	46,0
1511	151102		30			
1511	151103		35			
1511	151104		40			
1511	151106		25* 25	□		
1511	151107		30* 30	□		
1511	151108		40* 40	□		
1512	151201	21	25	126,0	128,7	58,65
1512	151202		30			
1512	151203		35			
1512	151204		40			
1512	151206		25* 25	□		
1512	151207		30* 30	□		
1512	151208		40* 40	□		
1513	151301	24	25	142,9	145,6	67,1
1513	151302		30			
1513	151303		35			
1513	151304		40			
1513	151306		25* 25	□		
1513	151307		30* 30	□		
1513	151308		40* 40	□		
1514	151401	25	25	149,0	151,7	70,15
1514	151402		30			
1514	151403		35			
1514	151404		40			
1514	151406		25* 25	□		
1514	151407		30* 30	□		
1514	151408		40* 40	□		

Ruota rinvio divisa, fresata

Split idler sprocket, machined / geteiltes Umlenkrad, gefräst

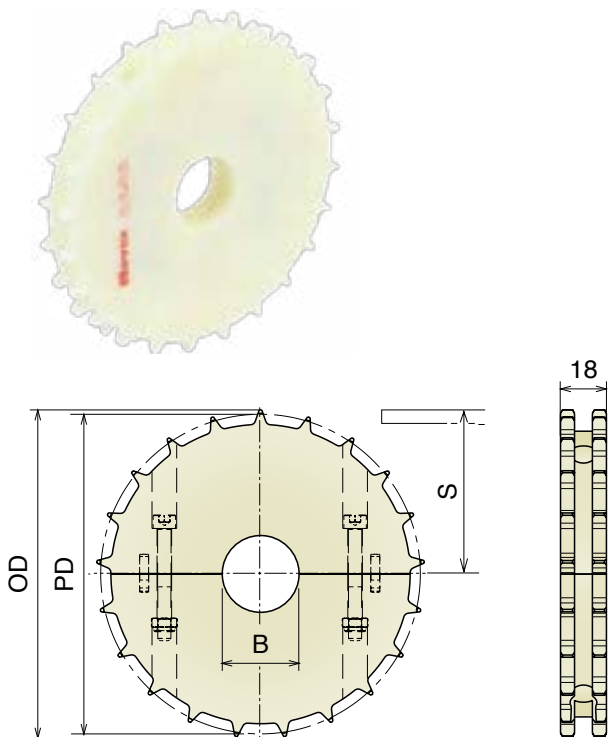

Part	Article-Nr.	Z-	Bore	PD	OD	S
1511	151150	17	18*	100,7	103,4	46,0
1511	151151		25			
1511	151152		30			
1511	151153		35			
1511	151154		40			
1512	151250	21	18*	126,0	128,7	58,65
1512	151251		25			
1512	151252		30			
1512	151253		35			
1512	151254		40			
1513	151350	24	18*	142,9	145,6	67,1
1513	151351		25			
1513	151352		30			
1513	151353		35			
1513	151354		40			
1514	151450	25	18*	149,0	151,7	70,15
1514	151451		25			
1514	151452		30			
1514	151453		35			
1514	151454		40			

*Plain Bore

Materiale / Material / Materialien:

Poliamide/Polyamide/Polyamid

Viti: Acciaio inox/Screws: Stainless steel/Schrauben: Edelstahl

Dadi: ferro zincato/Nuts: zinc plated steel/Mutter: verzinkter Stahl

550

Ruota traino divisa, fresata
Split drive sprocket, machined / geteiltes Antriebskettenrad, gefräst

Delivery: **Easy** Standard

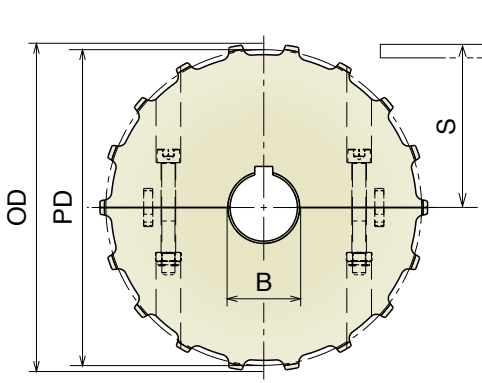

Part	Article-Nr.	Z	Bore	PD	OD	S
1521	152101	14	25	114,1	114,0	52,7
1521	152102		30			
1521	152103		35			
1521	152104		40			
1521	152106		25* 25	□		
1521	152107		30* 30	□		
1521	152108		40* 40	□		
1522	152201	16	25	130,2	130,0	60,7
1522	152202		30			
1522	152203		35			
1522	152204		40			
1522	152206		25* 25	□		
1522	152207		30* 30	□		
1522	152208		40* 40	□		
1523	152301	18	25	146,3	146,0	68,8
1523	152302		30			
1523	152303		35			
1523	152304		40			
1523	152306		25* 25	□		
1523	152307		30* 30	□		
1523	152308		40* 40	□		
1524	152401	20	25	162,4	162,0	76,8
1524	152402		30			
1524	152403		35			
1524	152404		40			
1524	152406		25* 25	□		
1524	152407		30* 30	□		
1524	152408		40* 40	□		

Ruota rinvio divisa, fresata

Split idler sprocket, machined / geteiltes Umlenrad, gefräst

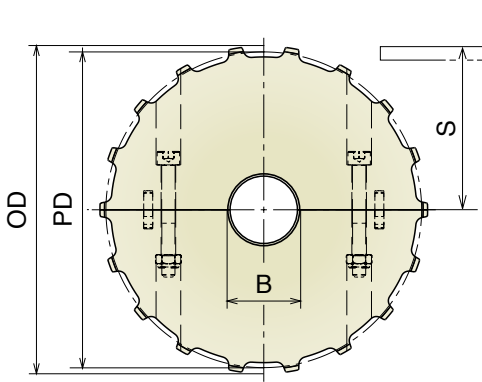
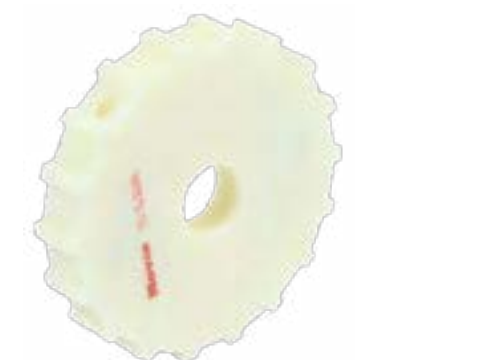

Part	Article-Nr.	Z	Bore	PD	OD	S
1521	152150	14	18*	114,1	114,0	52,7
1521	152151		25			
1521	152152		30			
1521	152153		35			
1521	152154		40			
1522	152250	16	18*	130,2	130,0	60,7
1522	152251		25			
1522	152252		30			
1522	152253		35			
1522	152254		40			
1523	152350	18	18*	146,3	146,0	68,8
1523	152351		25			
1523	152352		30			
1523	152353		35			
1523	152354		40			
1524	152450	20	18*	162,4	162,0	76,8
1524	152451		25			
1524	152452		30			
1524	152453		35			
1524	152454		40			

*Plain Bore

550 Ruota traino divisa, stampata

Split drive sprocket, molded / geteiltes Antriebskettenrad, gespritzt

Delivery: **Easy** **Standard**

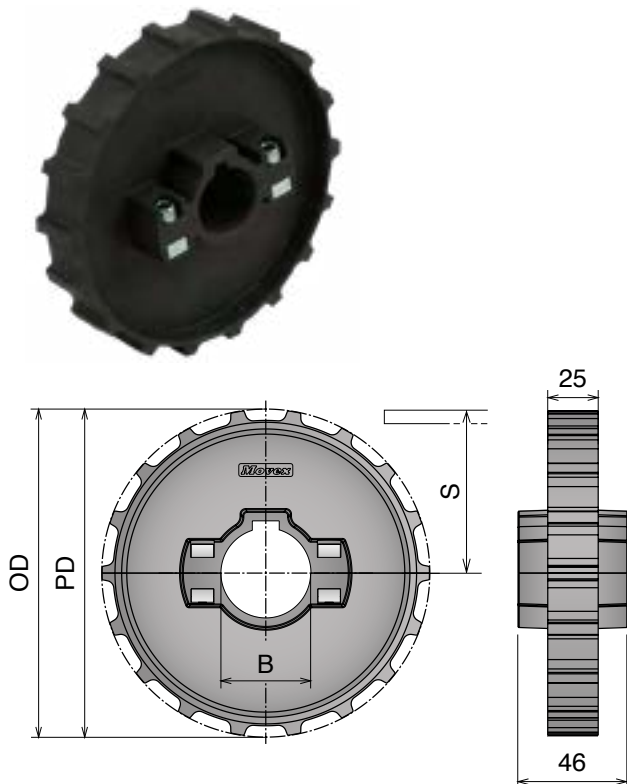

Part	Article-Nr.	Z-	Bore	PD	OD	S
1525	152501	14	25	114,1	114,0	52,7
1525	152502		30			
1525	152503		35			
1525	152504		40			
1525	152506		25* 25	□		
1525	152507		30* 30	□		
1525	152508		40* 40	□		
1526	152601	16	25	130,2	130,0	60,7
1526	152602		30			
1526	152603		35			
1526	152604		40			
1526	152606		25* 25	□		
1526	152607		30* 30	□		
1526	152608		40* 40	□		
1527	152701	18	25	146,3	146,0	68,8
1527	152702		30			
1527	152703		35			
1527	152704		40			
1527	152706		25* 25	□		
1527	152707		30* 30	□		
1527	152708		40* 40	□		
1528	152801	20	25	162,4	162,0	76,8
1528	152802		30			
1528	152803		35			
1528	152804		40			
1528	152806		25* 25	□		
1528	152807		30* 30	□		
1528	152808		40* 40	□		

Ruota rinvio divisa, stampata

Split idler sprocket, molded / geteiltes Umlenrad, gespritzt

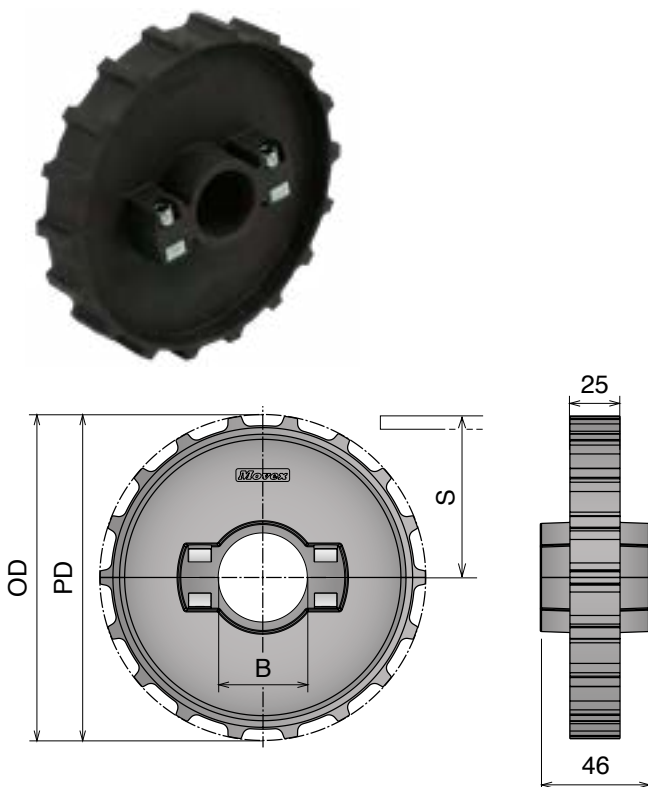

Part	Article-Nr.	Z-	Bore	PD	OD	S
1525	152551	14	25	114,1	114,0	52,7
1525	152552		30			
1525	152553		35			
1525	152554		40			
1526	152651	16	25	130,2	130,0	60,7
1526	152652		30			
1526	152653		35			
1526	152654		40			
1527	152751	18	25	146,3	146,0	68,8
1527	152752		30			
1527	152753		35			
1527	152754		40			
1528	152851	20	25	162,4	162,0	76,8
1528	152852		30			
1528	152853		35			
1528	152854		40			

Materiale / Material / Materialien:

Poliamide/Polyamide/Polyamid

Viti: Acciaio inox/Screws: Stainless steel/Schrauben: Edelstahl

Dadi: ferro zincato/Nuts: zinc plated steel/Mutter: verzinkter Stahl

550 PRO

Ruote per tappeti / Belt sprockets / Kettenräder für Mattenketten

550 PRO

Ruota traino divisa, fresata

Split drive sprocket, machined / geteiltes Antriebskettenrad, gefräst

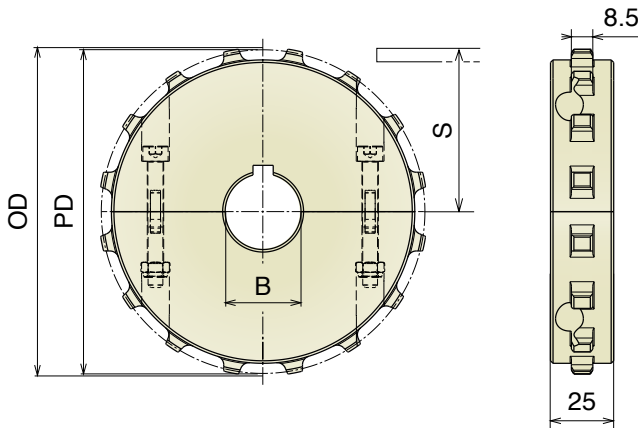

Part	Article-Nr.	Z	Bore	PD	OD	S
1640	164001	14	25	114,1	114,0	52,7
1640	164002		30			
1640	164003		35			
1640	164004		40			
1640	164006		25* 25			
1640	164007		30* 30			
1640	164008		40* 40			
1641	164101	16	25	130,2	130,0	60,7
1641	164102		30			
1641	164103		35			
1641	164104		40			
1641	164106		25* 25			
1641	164107		30* 30			
1641	164108		40* 40			
1642	164201	18	25	146,3	146,0	68,8
1642	164202		30			
1642	164203		35			
1642	164204		40			
1642	164206		25* 25			
1642	164207		30* 30			
1642	164208		40* 40			
1643	164301	20	25	162,4	162,0	76,8
1643	164302		30			
1643	164303		35			
1643	164304		40			
1643	164306		25* 25			
1643	164307		30* 30			
1643	164308		40* 40			

Ruota rinvio divisa, fresata

Split idler sprocket, machined / geteiltes Umlenrad,, gefräst

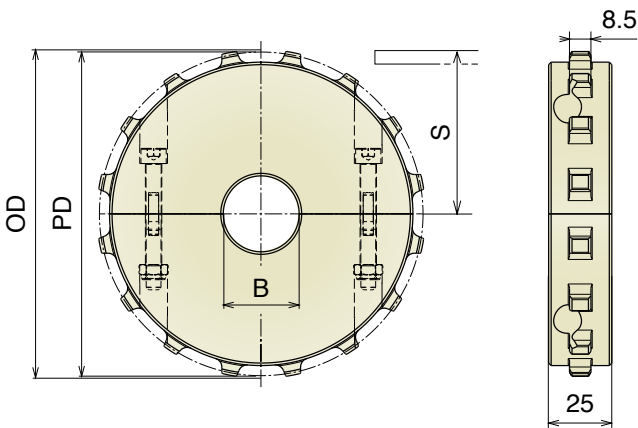

Part	Article-Nr.	Z	Bore	PD	OD	S
1640	164050	14	18*	114,1	114,0	52,7
1640	164051		25			
1640	164052		30			
1640	164053		35			
1640	164054		40			
1641	164150	16	18*	130,2	130,0	60,7
1641	164151		25			
1641	164152		30			
1641	164153		35			
1641	164154		40			
1642	164250	18	18*	146,3	146,0	68,8
1642	164251		25			
1642	164252		30			
1642	164253		35			
1642	164254		40			
1643	164350	20	18*	162,4	162,0	76,8
1643	164351		25			
1643	164352		30			
1643	164353		35			
1643	164354		40			

*Plain Bore

550 PRO

Ruote per tappeti / Belt sprockets / Kettenräder für Mattenketten

Materiale / Material / Materialien:

Poliammide rinforzato / Polyamide reinforced / Verstärktes Polyamid
 Viti: Acciaio inox / Screws: Stainless steel / Schrauben: Edelstahl
 Dadi: Ottone nichelato / Nuts: Nickel plated brass / Mutter: Messing

550 PRO

Ruota traino divisa, stampata

Split drive sprocket, molded / geteiltes Antriebskettenrad, gespritzt

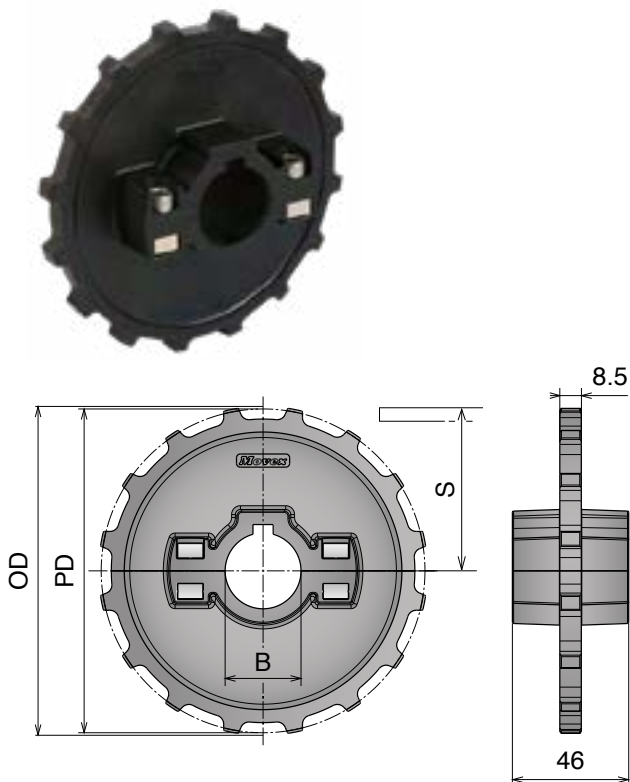

Part	Article-Nr.	Z-	Bore	PD	OD	S
1650	165001	14	25	114,1	114,0	52,7
1650	165002		30			
1650	165003		35			
1650	165004		40			
1650	165006		25*25	□		
1650	165007		30*30	□		
1650	165008		40*40	□		
1651	165101	16	25	130,2	130,0	60,7
1651	165102		30			
1651	165103		35			
1651	165104		40			
1651	165106		25*25	□		
1651	165107		30*30	□		
1651	165108		40*40	□		
1652	165201	18	25	146,3	146,0	68,8
1652	165202		30			
1652	165203		35			
1652	165204		40			
1652	165206		25*25	□		
1652	165207		30*30	□		
1652	165208		40*40	□		
1653	165301	20	25	162,4	162,0	76,8
1653	165302		30			
1653	165303		35			
1653	165304		40			
1653	165306		25*25	□		
1653	165307		30*30	□		
1653	165308		40*40	□		

Ruota rinvio divisa, stampata

Split idler sprocket, molded / geteiltes Umlenrad, gespritzt

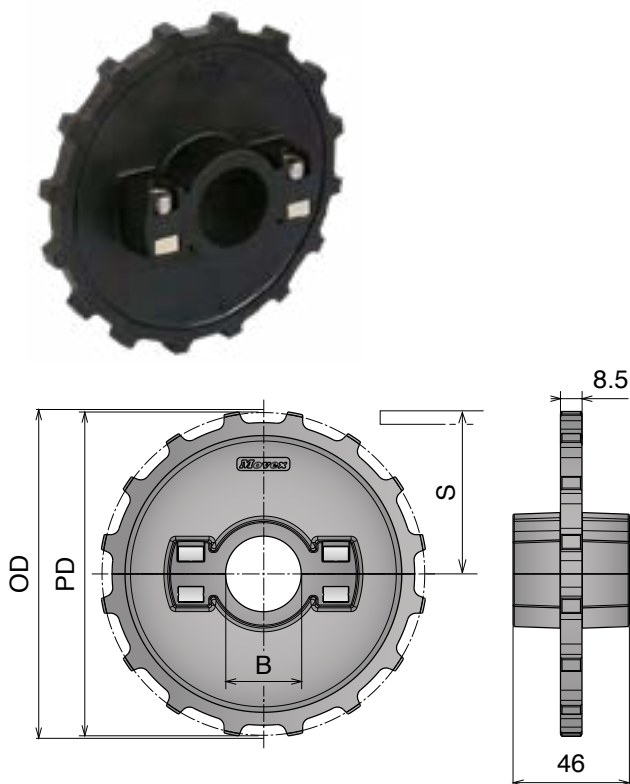

Part	Article-Nr.	Z-	Bore	PD	OD	S
1650	165051	14	25	114,1	114,0	52,7
1650	165052		30			
1650	165053		35			
1650	165054		40			
1651	165151	16	25	130,2	130,0	60,7
1651	165152		30			
1651	165153		35			
1651	165154		40			
1652	165251	18	25	146,3	146,0	68,8
1652	165252		30			
1652	165253		35			
1652	165254		40			
1653	165351	20	25	162,4	162,0	76,8
1653	165352		30			
1653	165353		35			
1653	165354		40			

Materiale / Material / Materialien:

Poliamide/Polyamide/Polyamid

Viti: Acciaio inox/Screws: Stainless steel/Schrauben: Edelstahl

Dadi: ferro zincato/Nuts: zinc plated steel/Mutter: verzinkter Stahl

551 Ruota traino divisa, fresata
Split drive sprocket, machined / geteiltes Antriebskettenrad, gefräst

Range Extension

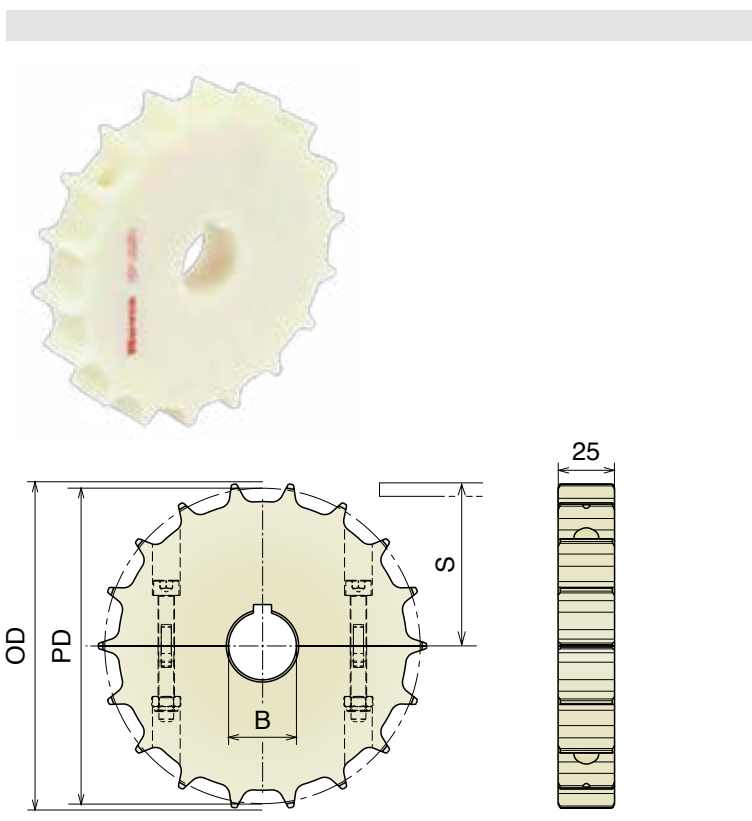

Part	Article-Nr.	Z-	Bore	PD	OD	S
1539	153901	11	25	90,2	92,0	39,7
1539	153902		30			
1539	153903E		35			
1539	153904E		40			
1539	153906		25* 25			
1539	153907		30* 30			
1539	153908E		40* 40			
1531	153101	14	25	114,2	113,5	50,7
1531	153102		30			
1531	153103		35			
1531	153104		40			
1531	153106		25* 25			
1531	153107		30* 30			
1531	153108		40* 40			
1532	153201	16	25	130,2	129,0	58,7
1532	153202		30			
1532	153203		35			
1532	153204		40			
1532	153206		25* 25			
1532	153207		30* 30			
1532	153208		40* 40			
1533	153301	18	25	146,3	145,3	66,7
1533	153302		30			
1533	153303		35			
1533	153304		40			
1533	153306		25* 25			
1533	153307		30* 30			
1533	153308		40* 40			
1534	153401	20	25	162,4	161,7	74,8
1534	153402		30			
1534	153403		35			
1534	153404		40			
1534	153406		25* 25			
1534	153407		30* 30			
1534	153408		40* 40			
1634	163401	21	25	170,4	169,7	78,9
1634	163402		30			
1634	163403		35			
1634	163404		40			
1634	163406		25* 25			
1634	163407		30* 30			
1634	163408		40* 40			

Ruota rinvio divisa, fresata
Split idler sprocket, machined / geteiltes Umlenrad, gefräst

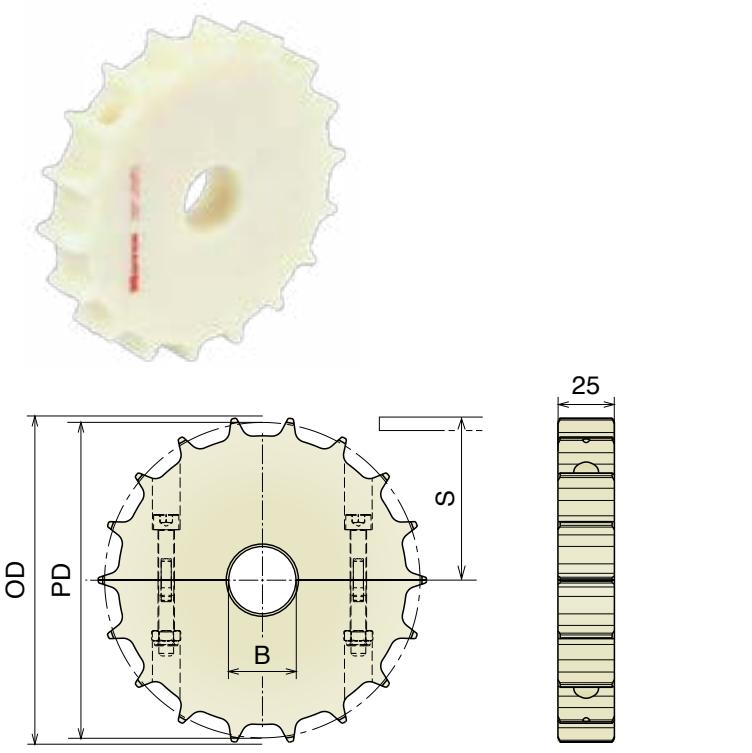

Part	Article-Nr.	Z-	Bore	PD	OD	S
1539	153950	11	18*	90,2	92,0	39,7
1539	153951		25			
1539	153952		30			
1539	153953E		35			
1539	153954E		40			
1531	153150	14	18*	114,2	114,0	50,7
1531	153151		25			
1531	153152		30			
1531	153153		35			
1531	153154		40			
1532	153250	16	18*	130,2	129,0	58,7
1532	153251		25			
1532	153252		30			
1532	153253		35			
1532	153254		40			
1533	153350	18	18*	146,3	145,3	66,7
1533	153351		25			
1533	153352		30			
1533	153353		35			
1533	153354		40			
1533	153354		40			
1534	153450	20	18*	162,4	161,7	74,8
1534	153451		25			
1534	153452		30			
1534	153453		35			
1534	153454		40			
1634	163450	21	18*	170,4	169,7	78,9
1634	163451		25			
1634	163452		30			
1634	163453		35			
1634	163454		40			

*Plain Bore

551

Ruota traino divisa, stampata

Split drive sprocket, molded / geteiltes Antriebskettenrad, gespritzt

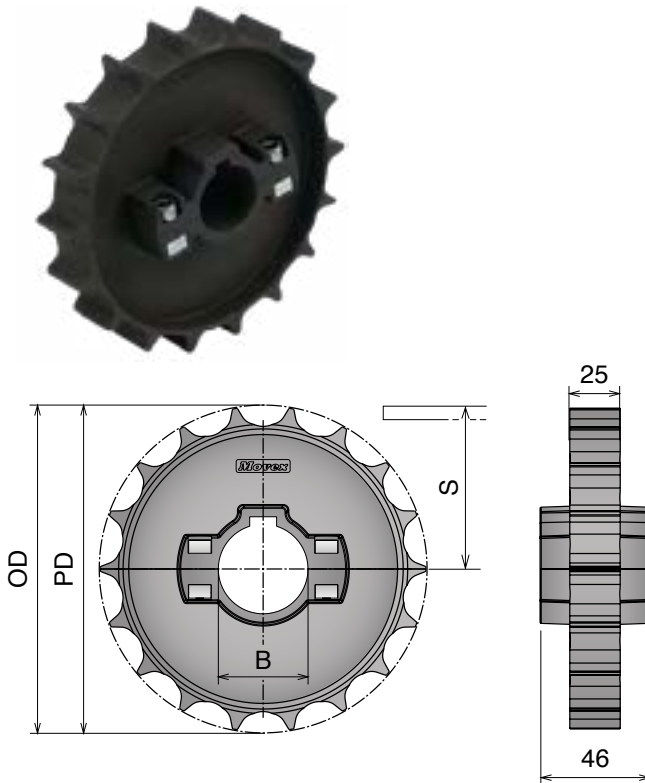
Delivery: **Easy** **Standard**

Part	Article-Nr.	Z-	Bore	PD	OD	S
1535	153501	14	25	114,2	113,5	50,7
1535	153502		30			
1535	153503		35			
1535	153504		40			
1535	153506		25*25	□		
1535	153507		30*30	□		
1535	153508		40*40	□		
1536	153601	16	25	130,2	129,0	58,7
1536	153602		30			
1536	153603		35			
1536	153604		40			
1536	153606		25*25	□		
1536	153607		30*30	□		
1536	153608		40*40	□		
1537	153701	18	25	146,3	145,3	66,7
1537	153702		30			
1537	153703		35			
1537	153704		40			
1537	153706		25*25	□		
1537	153707		30*30	□		
1537	153708		40*40	□		
1538	153801	20	25	162,4	161,7	74,8
1538	153802		30			
1538	153803		35			
1538	153804		40			
1538	153806		25*25	□		
1538	153807		30*30	□		
1538	153808		40*40	□		

Ruota rinvio divisa, stampata

Split idler sprocket, molded / geteiltes Umlenkrad, gespritzt

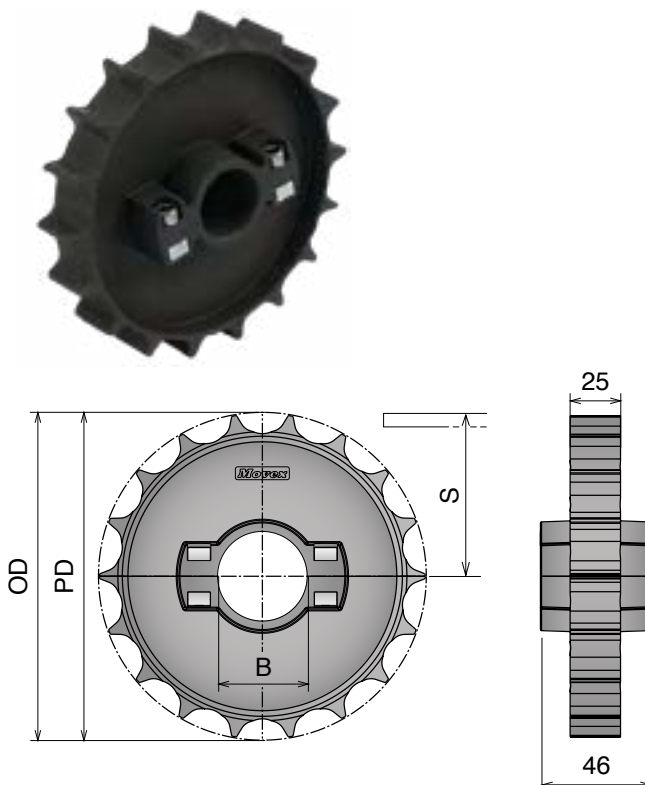

Part	Article-Nr.	Z-	Bore	PD	OD	S
1535	153551	14	25	114,2	113,5	50,7
1535	153552		30			
1535	153553		35			
1535	153554		40			
1536	153651	16	25	130,2	129,0	58,7
1536	153652		30			
1536	153653		35			
1536	153654		40			
1537	153751	18	25	146,3	145,3	66,7
1537	153752		30			
1537	153753		35			
1537	153754		40			
1538	153851	20	25	162,4	161,7	74,8
1538	153852		30			
1538	153853		35			
1538	153854		40			

552 Ruota traino divisa, fresata

Split drive sprocket, machined / geteiltes Antriebskettenrad, gefräst

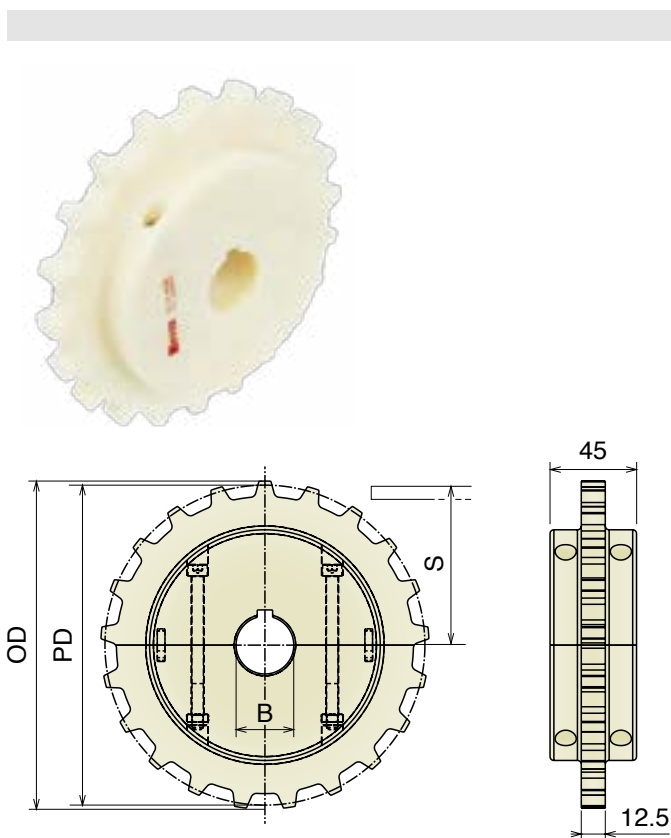

Part	Article-Nr.	Z-	Bore	PD	OD	S
1611	161101	16	25	130,2	130,6	58,7
1611	161102		30			
1611	161103		35			
1611	161104		40			
1611	161106		25* 25	□		
1611	161107		30* 30	□		
1611	161108		40* 40	□		
1612	161201	18	25	146,3	146,9	66,8
1612	161202		30			
1612	161203		35			
1612	161204		40			
1612	161206		25* 25	□		
1612	161207		30* 30	□		
1612	161208		40* 40	□		
1613	161301	21	25	170,4	170,7	78,8
1613	161302		30			
1613	161303		35			
1613	161304		40			
1613	161306		25* 25	□		
1613	161307		30* 30	□		
1613	161308		40* 40	□		
1614	161401	25	25	202,7	204,2	95,0
1614	161402		30			
1614	161403		35			
1614	161404		40			
1614	161406		25* 25	□		
1614	161407		30* 30	□		
1614	161408		40* 40	□		

Ruota rinvio divisa, fresata

Split idler sprocket, machined / geteiltes Umlenrad, gefräst

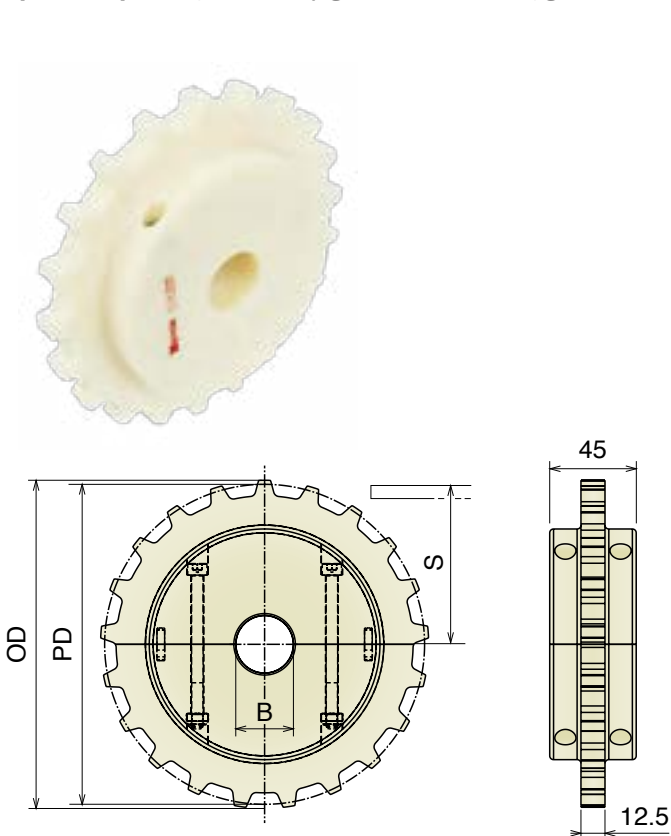

Part	Article-Nr.	Z-	Bore	PD	OD	S
1611	161150	16	18*	130,2	130,6	58,7
1611	161151		25			
1611	161152		30			
1611	161153		35			
1611	161154		40			
1612	161250	18	18*	146,3	146,9	66,8
1612	161251		25			
1612	161252		30			
1612	161253		35			
1612	161254		40			
1613	161350	21	18*	170,4	170,7	78,8
1613	161351		25			
1613	161352		30			
1613	161353		35			
1613	161354		40			
1614	161450	25	18*	202,7	204,2	95,0
1614	161451		25			
1614	161452		30			
1614	161453		35			
1614	161454		40			

556 Ruota traino divisa, fresata

Split drive sprocket, machined / geteiltes Antriebskettenrad, gefräst

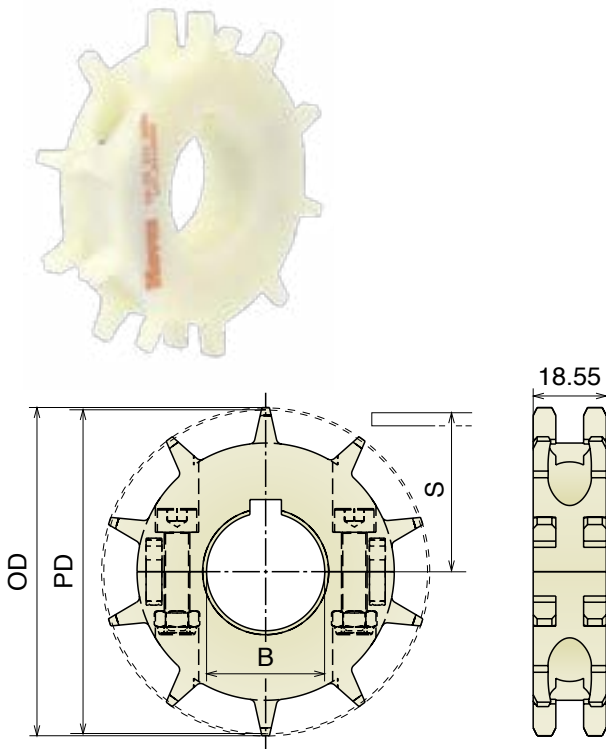

Part	Article-Nr.	Z-	Bore	PD	OD	S
1620	162001	10	25	82,2	83,3	33,0
1620	162002		30			
1620	162003E		35			
1620	162004E		40			
1620	162006		25* 25	□		
1620	162007		30* 30	□		
1620	162008E		40* 40	□		
1621	162101	12	25	98,1	100,0	41,0
1621	162102		30			
1621	162103		35			
1621	162104		40			
1621	162106		25* 25	□		
1621	162107		30* 30	□		
1621	162108E		40* 40	□		
1622	162201	15	25	122,2	124,3	53,0
1622	162202		30			
1622	162203		35			
1622	162204		40			
1622	162206		25* 25	□		
1622	162207		30* 30	□		
1622	162208		40* 40	□		
1623	162301	18	25	146,3	147,8	65,0
1623	162302		30			
1623	162303		35			
1623	162304		40			
1623	162306		25* 25	□		
1623	162307		30* 30	□		
1623	162308		40* 40	□		

Ruota rinvio divisa, fresata

Split idler sprocket, machined / geteiltes Umlenkrad, gefräst

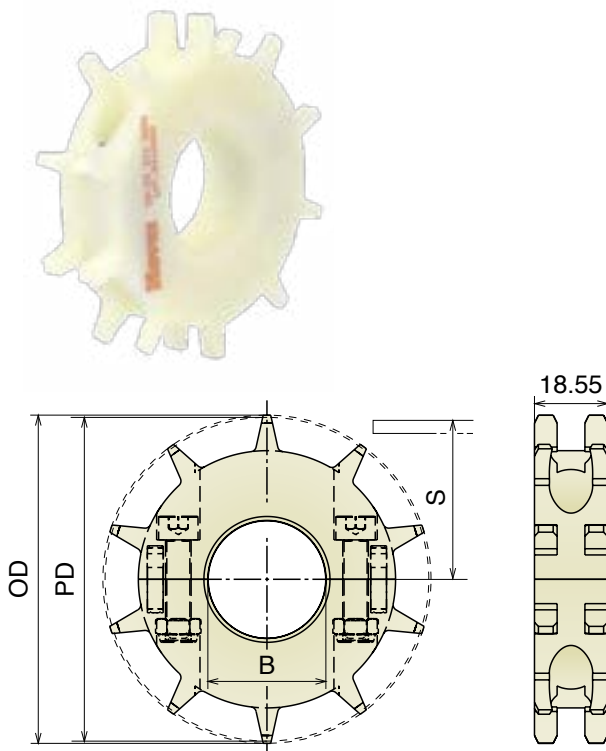

Part	Article-Nr.	Z-	Bore	PD	OD	S
1620	162050	10	18*	82,2	83,3	33,0
1620	162051		25			
1620	162052		30			
1620	162053E		35			
1620	162054E		40			
1621	162150	12	18*	98,1	100,0	41,0
1621	162151		25			
1621	162152		30			
1621	162153		35			
1621	162154		40			
1622	162250	15	18*	122,2	124,3	53,0
1622	162251		25			
1622	162252		30			
1622	162253		35			
1622	162254		40			
1623	162350	18	18*	146,3	147,8	65,0
1623	162351		25			
1623	162352		30			
1623	162353		35			
1623	162354		40			

Materiale / Material / Materialien:

Poliamide/Polyamide/Polyamid

Viti: Acciaio inox/Screws: Stainless steel/Schrauben: Edelstahl

Dadi: ferro zincato/Nuts: zinc plated steel/Mutter: verzinkter Stahl

260-261

Ruote per tappeti / Belt sprockets / Kettenräder für Mattenketten

260-261

Ruota traino divisa, fresata

Split drive sprocket, machined / geteiltes Antriebskettenrad, gefräst

Delivery: **Easy** **Standard**

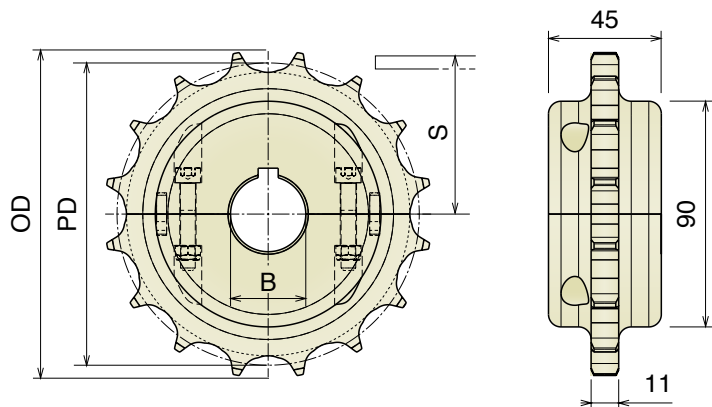

Part	Article-Nr.	Z-	Bore	PD	OD	S
1541	154101	16	25	128,9	130,9	67,8
1541	154102		30			
1541	154103		35			
1541	154104		40			
1542	154201	18	25	144,8	146,8	75,7
1542	154202		30			
1542	154203		35			
1542	154204		40			
1543	154301	19	25	154,3	156,3	80,5
1543	154302		30			
1543	154303		35			
1543	154304		40			

Ruota rinvio divisa, fresata

Split idler sprocket, machined / geteiltes Umlenrad, gefräst

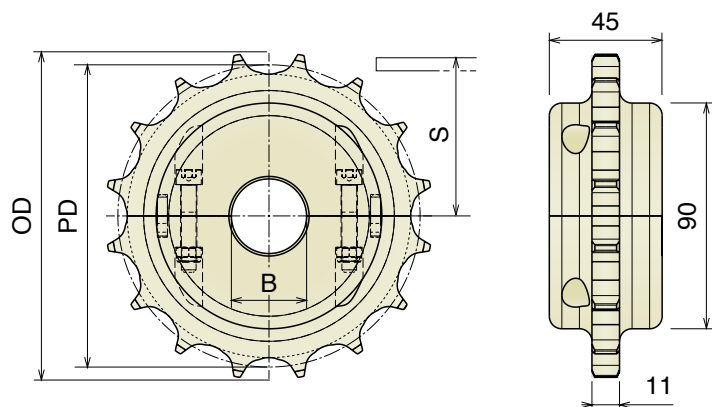

Part	Article-Nr.	Z-	Bore	PD	OD	S
1541	154150	16	18*	128,9	130,9	67,8
1541	154151		25			
1541	154152		30			
1541	154153		35			
1541	154154		40			
1542	154250	18	18*	144,8	146,8	75,7
1542	154251		25			
1542	154252		30			
1542	154253		35			
1542	154254		40			
1543	154350	19	18*	154,3	156,3	80,5
1543	154351		25			
1543	154352		30			
1543	154353		35			
1543	154354		40			

*Plain Bore

260-261

Ruota traino divisa, stampata
 Split drive sprocket, molded / geteiltes Antriebskettenrad, gespritzt

Delivery: **Easy** **Standard**

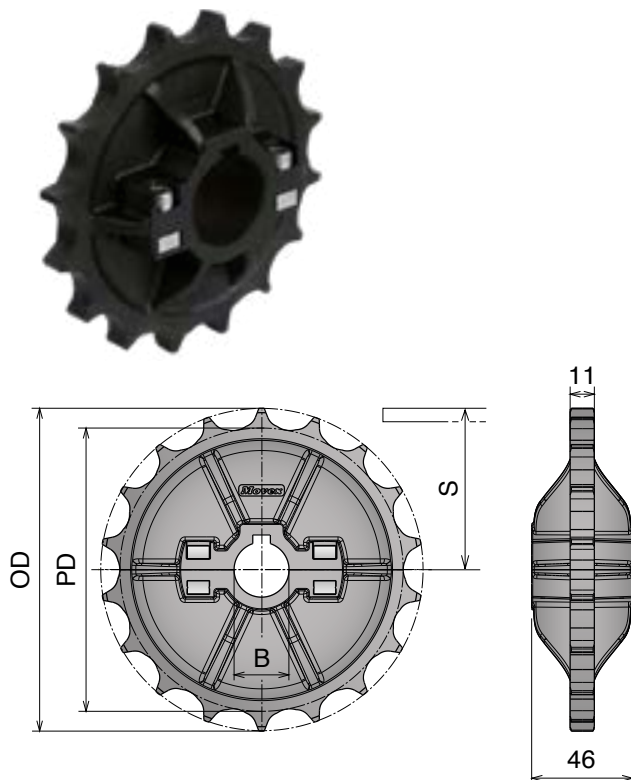

Part	Article-Nr.	Z-	Bore	PD	OD	S
1545	154501	16	25	128,9	130,9	67,8
1545	154502		30			
1545	154503		35			
1545	154504		40			
1545	154506		25*25	□		
1545	154507		30*30	□		
1545	154508		40*40	□		
1546	154601	18	25	144,8	146,8	75,7
1546	154602		30			
1546	154603		35			
1546	154604		40			
1546	154606		25*25	□		
1546	154607		30*30	□		
1546	154608		40*40	□		
1547	154701	19	25	154,3	156,3	80,5
1547	154702		30			
1547	154703		35			
1547	154704		40			
1547	154706		25*25	□		
1547	154707		30*30	□		
1547	154708		40*40	□		

Improved Design and Performance

Ruota rinvio divisa, stampata
 Split idler sprocket, molded / geteiltes Umlenkrad, gespritzt

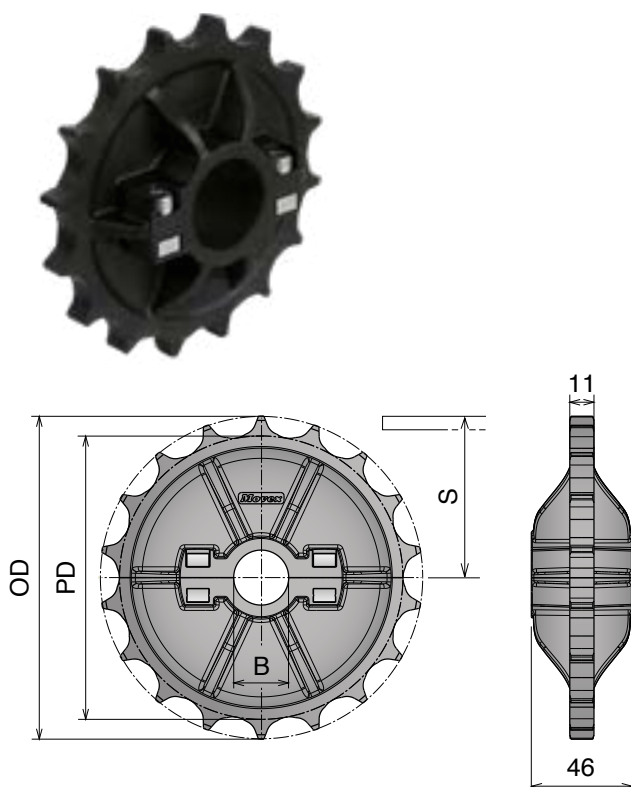

Part	Article-Nr.	Z-	Bore	PD	OD	S
1545	154551	16	25	128,9	130,9	67,8
1545	154552		30			
1545	154553		35			
1545	154554		40			
1546	154651	18	25	144,8	146,8	75,7
1546	154652		30			
1546	154653		35			
1546	154654		40			
1547	154751	19	25	154,3	156,3	80,5
1547	154752		30			
1547	154753		35			
1547	154754		40			

Improved Design and Performance

Materiale / Material / Materialien:

Poliammide/Polyamide/Polyamid

Viti: Acciaio inox/Screws: Stainless steel/Schrauben: Edelstahl

Dadi: ferro zincato/Nuts: zinc plated steel/Mutter: verzinkter Stahl

600

Ruote per tappeti / Belt sprockets / Kettenräder für Mattenketten

600

Ruota traino divisa, fresata
Split drive sprocket, machined / geteiltes Antriebskettenrad, gefräst

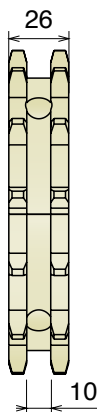
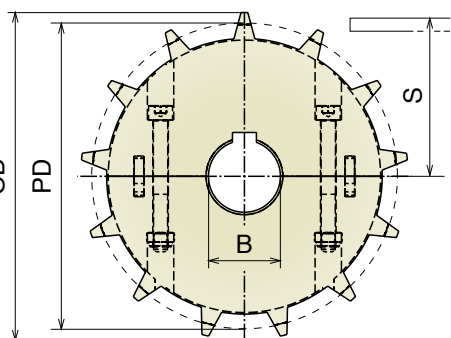
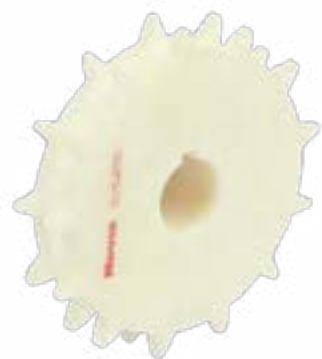

Part	Article-Nr.	Z-	Bore	PD	OD	S
1571	157101	10	25	102,8	107,7	45,0
1571	157102		30			
1571	157103		35			
1571	157104		40			
1572	157201	13	25	132,7	138,8	60,0
1572	157202		30			
1572	157203		35			
1572	157204		40			
1573	157301	15	25	152,7	159,4	70,0
1573	157302		30			
1573	157303		35			
1573	157304		40			
1574	157401	16	25	162,8	169,6	75,0
1574	157402		30			
1574	157403		35			
1574	157404		40			

Ruota rinvio divisa, fresata

Split idler sprocket, machined / geteiltes Umlenrad, gefräst

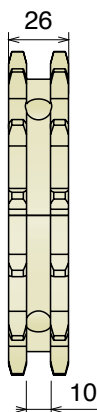
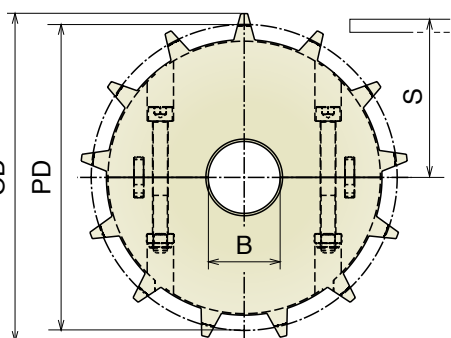

Part	Article-Nr.	Z-	Bore	PD	OD	S
1571	157150	10	18*	102,8	107,7	45,0
1571	157151		25			
1571	157152		30			
1571	157153		35			
1571	157154		40			
1572	157250	13	18*	132,7	138,8	60,0
1572	157251		25			
1572	157252		30			
1572	157253		35			
1572	157254		40			
1573	157350	15	18*	152,7	159,4	70,0
1573	157351		25			
1573	157352		30			
1573	157353		35			
1573	157354		40			
1574	157450	16	18*	162,8	169,6	75,0
1574	157451		25			
1574	157452		30			
1574	157453		35			
1574	157454		40			

*Plain Bore

600 Support sprocket/Split support roller

Ruote per tappeti / Belt sprockets / Kettenräder für Mattenketten

• Materiale / Material / Materialien:

Poliammide/Polyamide/Polyamid

Viti: Acciaio inox/Screws: Stainless steel/Schrauben: Edelstahl

Dadi: ferro zincato/Nuts: zinc plated steel/Mutter: verzinkter stahl

600 Support sprocket

Ruota traino divisa, fresata

Split drive sprocket, machined / geteiltes Antriebskettenrad gefräst

Designed to support Small radius section

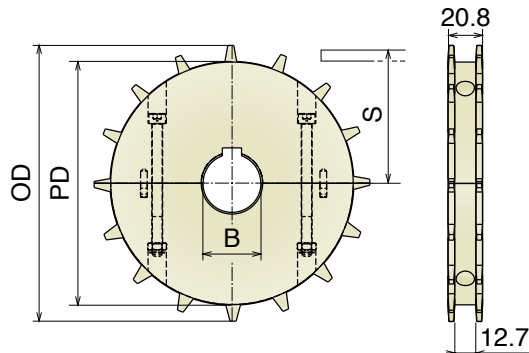
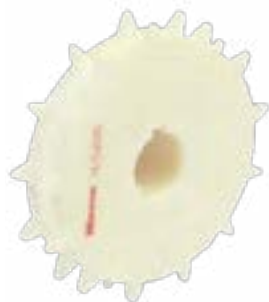

Article-Nr.	Z-	Bore	PD	OD	S
157101SR	10	25	102,8	107,7	45,0
157102SR		30			
157103SR		35			
157104SR		40			
157201SR	13	25	132,7	138,8	60,0
157202SR		30			
157203SR		35			
157204SR		40			
157301SR	15	25	152,7	159,4	70,0
157302SR		30			
157303SR		35			
157304SR		40			
157401SR	16	25	162,8	169,6	75,0
157402SR		30			
157403SR		35			
157404SR		40			

Ruota rinvio divisa, fresata

Split idler sprocket, machined / geteiltes Umlenkrad, gefräst

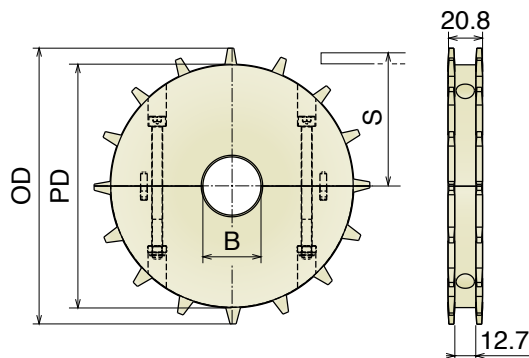
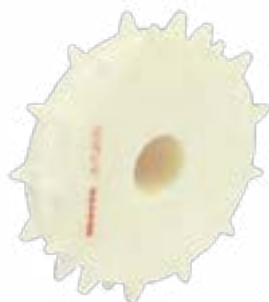

Article-Nr.	Z-	Bore	PD	OD	S
157150SR	10	18*	102,8	107,7	45,0
157151SR		25			
157152SR		30			
157153SR		35			
157154SR		40			
157250SR	13	18*	132,7	138,8	60,0
157251SR		25			
157252SR		30			
157253SR		35			
157254SR		40			
157350SR	15	18*	152,7	159,4	70,0
157351SR		25			
157352SR		30			
157353SR		35			
157354SR		40			
157450SR	16	18*	162,8	169,6	75,0
157451SR		25			
157452SR		30			
157453SR		35			
157454SR		40			

*Plain Bore

600 Split support roller

Ruota traino divisa, fresata

Split drive sprocket, machined / geteiltes Antriebskettenrad gefräst

Designed to support Small radius section

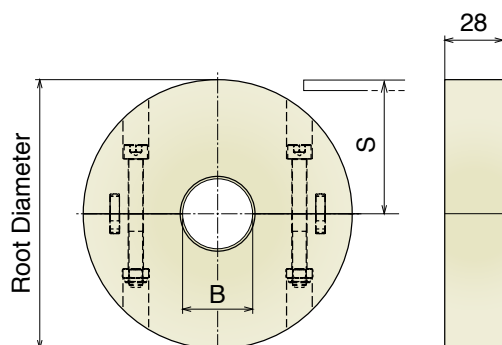

Article-Nr.	Z- eq.	Bore	Root Ø	S
157150R	10	18*	85,1	45,0
157151R		25		
157152R		30		
157153R		35		
157154R		40		
157250R	13	18*	115,0	60,0
157251R		25		
157252R		30		
157253R		35		
157254R		40		
157350R	15	18*	134,3	70,0
157351R		25		
157352R		30		
157353R		35		
157354R		40		
157450R	16	18*	146,8	75,0
157451R		25		
157452R		30		
157453R		35		
157454R		40		

TECHNICAL RECOMMENDATION:



Fix Split support roller with split collars Part 215 Pag 357

ZERO CONTACT

Ruota traino, fresata
Drive sprocket, machined / Antriebskettenrad, gefräst

New

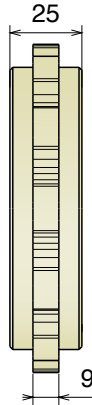
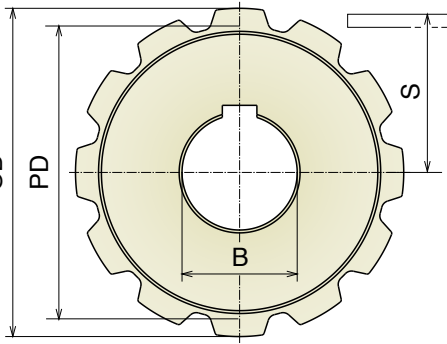

Part	Article-Nr.	Z-	Bore	R min.	PD	OD	S
1624	162401	12	40	650	58,0	61,0	25,6
1624	162402			750	66,0	69,0	29,9
1624	162403			850	76,0	79,0	34,2
1624	162404			950	84,0	86,0	38,5
1624	162405			1050	94,0	97,0	42,8
1624	162406			1150	102,0	104,0	47,1
1624	162407			1250	112,0	114,0	51,4
1624	162408			1350	119,0	122,0	55,7
1624	162409			1450	130,0	132,0	60,0
1624	162410			1550	137,0	140,0	64,3
1624	162411			1650	145,0	148,0	68,6
1624	162412			1750	144,0	157,0	72,9
1624	162413			1850	163,0	166,0	77,2
1624	162414			1950	171,0	174,0	81,5
1624	162415			2050	180,0	183,0	85,8
1624	162416			2150	189,0	192,0	90,1

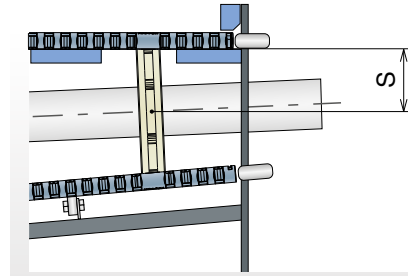

ZERO CONTACT PRO

Ruota traino, fresata
Drive sprocket, machined / Antriebskettenrad, gefräst

New

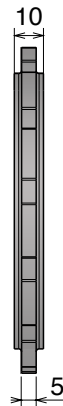
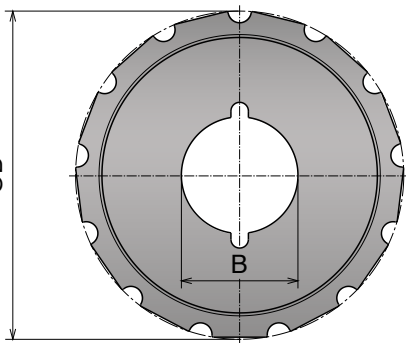

Part	Article-Nr.	Z-	Bore	OD
1633	163301	13	30	45,9
1633	163302		40	52,0
1633	163303			58,0
1633	163304			64,1
1633	163305			70,2
1633	163306			76,2
1633	163307			82,3
1633	163308			88,3
1633	163309			94,4
1633	163310			100,5
1633	163311			106,6
1633	163312			112,6
1633	163313			118,7
1633	163314			124,7
1633	163315			130,8
1633	163316			136,9
1633	163317			142,9

500 RR

Ruote per tappeti / Belt sprockets / Kettenräder für Mattenketten

Materiali / Material / Materialien:

Poliammide/Polyamide/Polyamid

Viti: Acciaio inox/Screws: Stainless steel/Schrauben: Edelstahl

Dadi: ferro zincato/Nuts: zinc plated steel/Mutter: verzinkter Stahl

500 RR

Ruota traino, stampata

Drive sprocket, molded / Antriebskettenrad, gespritzt

Delivery: **Easy** **Standard**

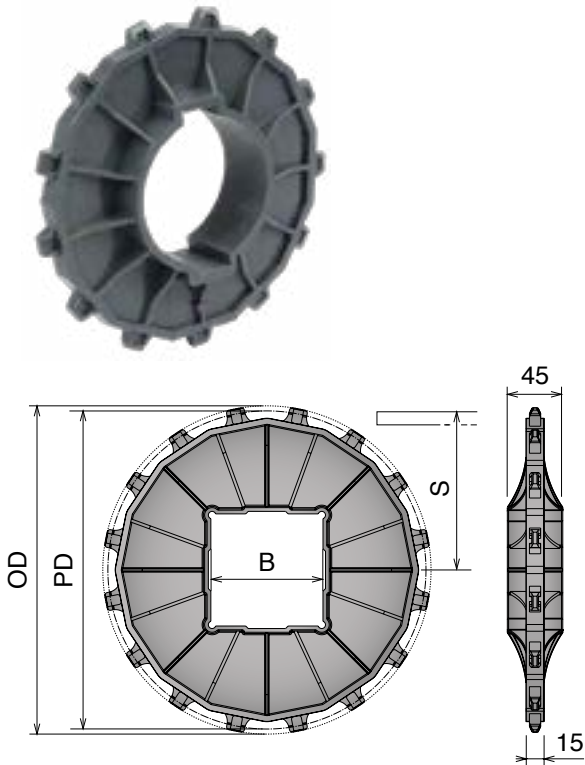

Part	Article-Nr.	Z-	Bore	PD	OD	S
1551	155104	10	Ø40	164,4	163,1	74,2
1551	155105		Ø50			
1551	155106		40x40			
1551	155107		60x60			
1551	155108		65x65			
1552	155204	12	Ø40	196,3	196,3	90,1
1552	155206		40x40			
1552	155207		60x60			
1552	155208		65x65			
1553	155311	13	Ø65	212,3	209,0	98,1
1553	155310		Ø90			
1553	155306		40x40			
1553	155307		60x60			
1553	155308		65x65			
1553	155309		90x90			
1559	155910	16	Ø90	260,4	262,0	122,3
1559	155905		Ø2,5"			
1559	155908		65x65			
1559	155909		90x90			
1559	155912		120x120			

Ruota traino, fresata

Drive sprocket, machined / Antriebskettenrad, gefräst

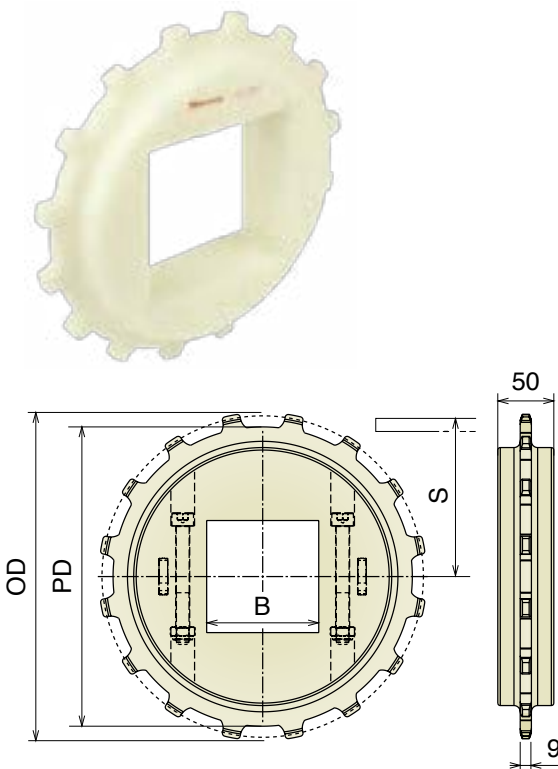

Part	Article-Nr.	Z-	Bore	PD	OD	S
1607	160704	10	Ø40	164,4	163,1	74,2
1607	160705		Ø50			
1607	160706		40x40			
1607	160707		60x60			
1607	160708		65x65			
1608	160804	12	Ø40	196,3	196,3	90,1
1608	160806		40x40			
1608	160807		60x60			
1608	160808		65x65			
1609	160911	13	Ø65	212,3	209,0	98,1
1609	160910		Ø90			
1609	160906		40x40			
1609	160907		60x60			
1609	160908		65x65			
1609	160909		90x90			
1610	161010	16	Ø90	260,4	262,0	122,3
1610	161005		Ø2,5"			
1610	161008		65x65			
1610	161009		90x90			
1610	161012E		120x120			

Materiale / Material / Materialien:

Resina acetica/Acetal resin/Azetal

Viti: Acciaio inox/Screws: Stainless steel/Schrauben: Edelstahl

Dadi: Acciaio inox/Nuts: Stainless steel/Mutter: Edelstahl

500 RR Split Version

Ruote per tappeti / Belt sprockets / Kettenräder für Mattenketten

500 RR Split Version

Ruota traino, stampata / Drive sprocket, molded / Antriebskettenrad, gespritzt

Delivery: **Easy** Standard

Part	Article-Nr.	Z-	Bore	PD	OD	S
1558	155810	16	Ø 90 with double keyway	260,4	262,0	122,3



Advantages:

- ▶ Easy Clean
- ▶ Easy installation
- ▶ Heavy duty design

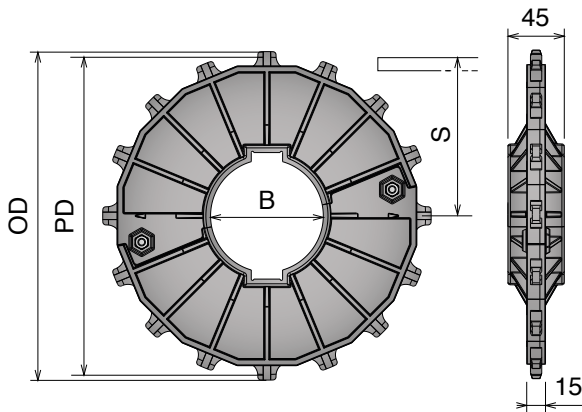

Ruota rinvio divisa, stampata

Split idler sprocket, molded / geteiltes Umlenkrad, gespritzt

Part	Article-Nr.	Z-	Bore (B)	Bore (B ₁ x B ₁)	PD	OD	S
1558	155809	16	Ø 100	90 x 90	260,4	262,0	122,3

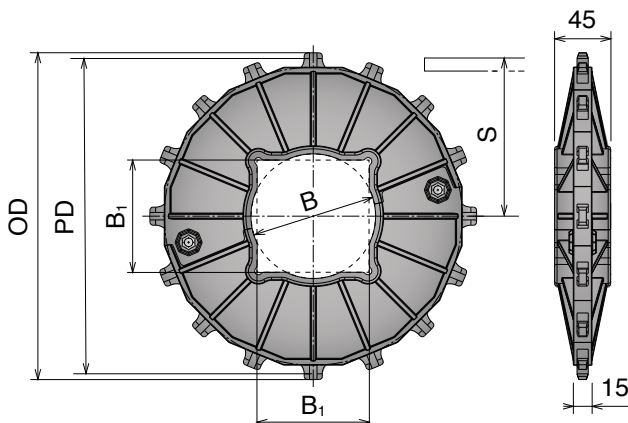

BluLub è un nuovo materiale ad alte prestazioni composto da lubrificanti solidi di ultima generazione UHMW-PE. **BluLub** migliora il limite PV rispetto allo standard UHMW-PE, soprattutto nelle applicazioni dove la lubrificazione è limitata o assente e le velocità e/o i carichi sono elevati. **BluLub** ti fa consumare meno energia e con un basso coefficiente di attrito, migliora la stabilità del prodotto, l'usura della catene e de nastri modulari allungandone la vita utile.

BluLub is a new high-performance compounded UHMW-PE material with the latest generation of solid lubricants. **BluLub** contributes to improve PV-properties compared to standard UHMW-PE, especially in applications with limited lubrication, higher speeds and/or higher loads. **BluLub** requires less energy and with the lower coefficient of friction, improves the product stability and wear life of chains and modular belts.

BluLub ist ein neues High-Performance UHMW-PE Material mit der neuesten Generation von festen Schmierstoffen. **BluLub** trägt dazu bei die PV-Eigenschaften im Vergleich zu Standard-UHMW-PE zu verbessern, vor allem in Anwendungen mit begrenzter Schmierung, höheren Geschwindigkeiten und / oder höheren Lasten. Mit **BluLub** wird weniger Energie benötigt. Mit dem niedrigeren Reibungskoeffizienten, verbessert sich die Produktstabilität. Die Standzeiten von Ketten und Modulbändern werden erhöht.

Properties:

- UHMW-PE Polyethylene with molecular density 5,600,000 g/mol or 9,200,000 g/mol.
- Operating temperature: -40 to 176°F (-40 to + 80°C)
- BluLub complies with the Code of Federal Regulations of FDA

Advantages:

- Running dry
- High speed
- Reduced noise and squeaking
- Lower Coefficient of Friction
- Lower wear
- Less energy consumption
- Minimal moisture absorption
- Smooth and quite chain running

Vorteile

- Trockenlauf
- Hohe Geschwindigkeit
- Reduzierte Geräuschentwicklung und kein "Quietschen"
- Niedrigerer Reibwert
- Geringerer Verschleiß
- Weniger Energieverbrauch
- Minimale Feuchtigkeitsaufnahme
- Ruhiger Lauf der Kette

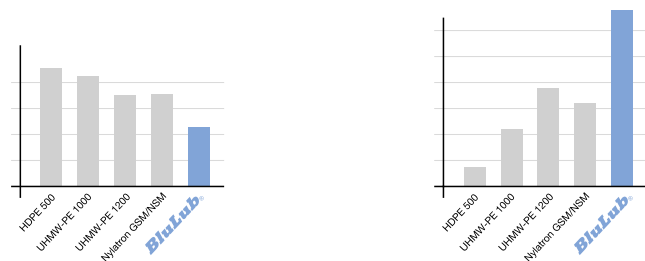

Coefficient of friction (average)

Relative wearlife

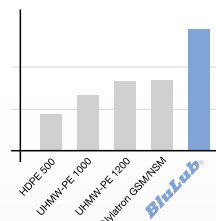

Max speed
max. recommended surface speed (dry-acetal LF chain)

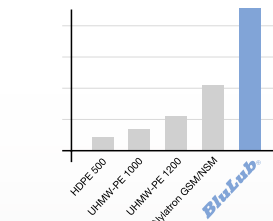

PV-limit

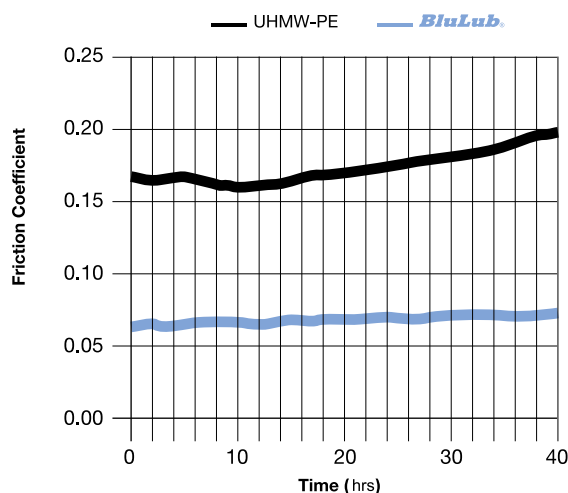

Less Friction Compared to UHMW-PE

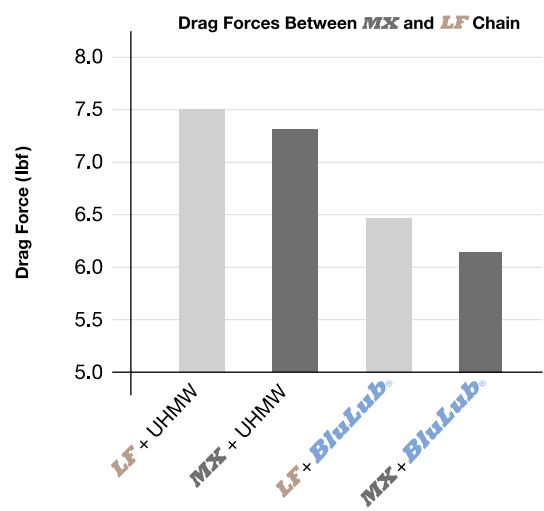

Chain / Wear Strip Configuration

2019

Movex[®]
Global Thinking, Local Acting.

WE CREATE SOLUTIONS

Movex designs and manufactures high quality components for the food, beverage, packaging, automotive and automation industries.

Movex meets your needs for standard and custom products in a dynamic and responsive way ensuring always the best performance.

Movex S.p.A.

Via Industria, 22
24060 Castelli Calepio (BG)

P +39 035 8359711
F +39 035 4420873



info@movexii.com
movexii.com

Movex around the world

Movex GmbH
P +49-6204-9375-0

Movex Brasil Ltda
P +55-15-3141-2550

Movex France
P +33-0640592049

Movex AG India
P +91-120-4159660-62

Movex Russia
P +7 (495) 925-88-56

Movex UK Ltd.
P +44-77-20678442

Movex Nederland
P +31-630-994850

Movex USA Inc.
P +1-919-274-5477

Movex SA de CV
P +52-1-3318458187

Movex Ukraine
P +380-667507756